

SG-43 Series

Sound-proof Central Granulators

Date: Nov, 2014

Version: Ver.B (English)



Contents

1. General Description	9
1.1 Coding Principle	10
1.2 Feature	10
1.3 Technical Specifications	12
1.3.1 Technical Specifications	12
1.3.2 Dimensions	13
1.4 Safety Regulations	13
1.4.1 Safety Signs and Labels	13
1.4.2 Transportation and Storage of the Machine	16
1.5 Exemption Clause	18
2. Structural Features and Working Principle	19
2.1 General Description	19
2.1.1 Working Principle	19
2.2 Safety System	20
2.2.1 Emergency Stop	20
2.2.2 Safety Switch	20
2.2.3 Long Star Screw	21
2.3 Assembly Drawing	22
2.3.1 Assembly Drawing	22
2.3.2 Parts List	23
2.3.3 Cutting Chamber	25
2.3.4 Cutting Chamber Parts List	25
2.3.5 Blade Rest	26
2.3.6 Transmission Parts	27
2.3.7 Transmission Parts Parts List	27
2.3.8 Screen	28
2.3.9 Screen Parts List	28
2.3.10 Screen Bracket	28
2.3.11 Screen Bracket Parts List	28
2.3.12 Blower	29
2.3.13 Blower Parts List	29

2.3.14	Feed Box, Insulative Box and Shutter.....	30
2.3.15	Feed Box, Insulative Box and Shutter Parts List.....	30
2.3.16	Regrind Storage Bin	31
2.3.17	Regrind Storage Bin Parts List	31
2.4	Wiring Diagram	32
2.4.1	Main Circuit.....	32
2.4.2	Control Wiring Diagram	33
2.4.3	Electrical Components Layout	35
2.4.4	Electrical Components List	37
2.5	Electrical Components Instruction.....	43
2.6	Optional Accessories	44
2.6.1	DS-43 Dust separate System	44
2.6.2	Clean	46
2.6.3	Screen	46
2.6.4	Cutters	46
3.	Installation and Debugging.....	47
3.1	Installation Notice.....	49
3.2	Installation Place	49
3.3	Installation of Bearing and Blade Rest	50
3.4	Installation of Fixed Blades and Rotating Blades	51
3.5	Installation of Belt Pulley and Motor	52
3.6	Installation of Regrind Storage Bin, Screen and Screen Bracket.....	53
3.7	Installation of Feed Box and Feed Inlet.....	54
4.	Operation Guide	55
4.1	Startup Pretest	55
4.1.1	Before the First Startup.....	55
4.1.2	After First Startup for 2 Hours.....	55
4.1.3	After First Startup for 20~30 Hours.....	56
4.2	Circuit Connection.....	56
4.2.1	Check the Running Direction of the Motor	56
4.2.2	Check the Running Direction of the Blower	57
4.3	Open the Feeding Hopper, Screen and the Regrind Storage Bin	57
4.3.1	Open the Feeding Hopper	57
4.3.2	Open the Regrind Storage Bin and Screen	58

4.4	Close the Screen Bracket; the Regrind Storage bin and the Feeding Hopper.....	58
4.4.1	Installation of the Screen Bracket and the Regrind Storage Bin.....	58
4.5	Turn Off and Stop the Granulator.....	59
4.6	Blades Installation Adjusting	59
5.	Trouble Shooting.....	61
5.1	Granulator Can Not Work.....	61
5.2	Stop Due to Other Reasons	61
6.	Maintenance and Repair	63
6.1	Repair	63
6.1.1	Replace the Blades.....	63
6.2	Transferring.....	65
6.2.1	Daily Maintenance of V Belts.....	65
6.2.2	Adjustments of V Belts.....	66
6.3	Lubrication	66
6.3.1	Lubricating Oils.....	66
6.3.2	Please Grease the Bearing with Lubricating Oils Periodically	67
6.4	Maintenance	67
6.4.1	Daily Check	67
6.4.2	Weekly Check.....	68
6.4.3	Monthly Check.....	68
6.5	Cleaning.....	68
6.6	Maintenance Schedule.....	70
6.6.1	About the Machine.....	70
6.6.2	Check After Installation.....	70
6.6.3	Daily Check	70
6.6.4	Weekly Check.....	70
6.6.5	Monthly Check.....	71
6.6.6	Check Half-yearly or Every 1000 Running Hours	71
6.6.7	3 year Checking.....	71

Table index

Table 1-1: Technical Specifications.....	12
--	----

Table 2-1: Parts List	23
Table 2-2: Cutting Chamber Parts List	25
Table 2-3: Blade Rest Parts List	26
Table 2-4: Transmission Parts Parts List	27
Table 2-5: Screen Parts List.....	28
Table 2-6: Screen Bracket Parts List.....	28
Table 2-7: Blower Parts List	29
Table 2-8: Feed Box, Insulative Box and Shutter Parts List	30
Table 2-9: Regrind Storage Bin Parts List.....	31
Table 2-10: SG-4360 Electrical Components List	37
Table 2-11: SG-4360H/4390 Electrical Components List.....	39
Table 2-12: SG-4390H Electrical Components List.....	41
Table 2-13: Parts list of Installation Illustrative	44

Picture index

Picture 1-1: Dimensions	13
Picture 2-1: Working Principle	19
Picture 2-2: Emergency Stop	20
Picture 2-3: Safety Switch	21
Picture 2-4: Screw Shaft	21
Picture 2-5: Assembly Drawing	22
Picture 2-6: Cutting Chamber.....	25
Picture 2-7: Blade Rest	26
Picture 2-8: Transmission Parts	27
Picture 2-9: Screen	28
Picture 2-10: Screen Bracket	28
Picture 2-11: Blower.....	29
Picture 2-12: Feed Box, Insulative Box and Shutter.....	30
Picture 2-13: Regrind Storage Bin.....	31
Picture 2-14: Main Circuit.....	32
Picture 2-15: Control Wiring Diagram 1.....	33
Picture 2-16: Control Wiring Diagram 2.....	34
Picture 2-17: Electrical Components Layout (Opt for Safety Relay).....	35

Picture 2-18: Electrical Components Layout (Not Opt for Safety Relay)	36
Picture 2-19: Electrical Components Instruction	43
Picture 2-20: Installation Illustrative Photo	44
Picture 2-21: Screen	46
Picture 3-1: Installation Place 1	49
Picture 3-2: Installation Place 2	50
Picture 3-3: Installation of Bearing and Blade Rest	51
Picture 3-4: Installation of Fixed Blades and Rotating Blades	51
Picture 3-5: Installation of Belt Pulley and Motor	53
Picture 3-6: Installation of Regrind Storage Bin, Screen and Screen Bracket	53
Picture 3-7: Installation of Feed Box and Feed Inlet	54
Picture 4-1: Position-adjusting Screws	56
Picture 4-2: Blower	57
Picture 4-3: Close the screen bracket; the regrind storage bin and the feeding hopper	58
Picture 4-4: Circuit switch	59
Picture 4-5: Blades Installation Adjusting	60
Picture 6-1: Remove the Rotating Blades	64
Picture 6-2: Daily Maintenance of V Belts	66
Picture 6-3: Oil throat	67
Picture 6-4: Star Screw	68

1. General Description



Please read this manual carefully before using this machine in order to operate correctly against any damage caused due to improper operation.



Note!

Always take great care when the knives are within reach, they are very sharp and can cause personal injury.



Forbidden to process flammable or toxic material!

SG-43 series are suitable for centralized recycling of waste and rejected parts from injection, blowing molding and extrusion lines. This series feature compact design, easy operation and quick blade replacement. Gradually inclined cutting and integrated power design offer a better cutting effect and a lower noise level, ensures low energy consumption.



Model: SG-4360

1.1 Coding Principle

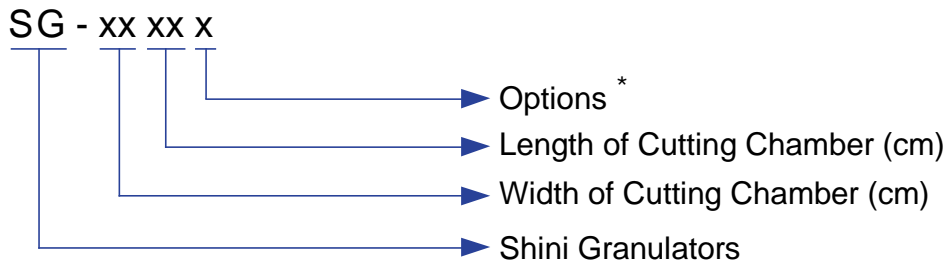

Note: *

H=Higher Motor Power F=Fiber-added FAD=Full-receiver Alarm Device
R=For Stainless Steel Made Feed Port and Storage Tank CE=CE Conformity

1.2 Feature

Standard configuration

- 1) Optimized structure and full-closed sound-proofing ensure low noise level.
- 2) Cutting chamber made of high rigidity material, after processing by CNC machine, has the features like high intensity, super wearability, no contamination, long service life and easy for maintenance and repairing.
- 3) The initial cut-off point of machine with cutting chamber design is high, applicable to grind thick walled objects and sheet.
- 4) Paddle blades design allows increased efficiency.
- 5) The cutters are made of imported high quality steel featuring wearability, high rigidity and reusable after sharpening.
- 6) Equipped with presetting knife jig, simple cutter installation adjusting technology makes the rotating blades be adjusted within clamps outside machine, no longer needs to be adjusted from inside of machine as before.
- 7) Equipped with electrical current relay, motor overload protector and multiple safety devices, to ensure safe operation.
- 8) Regrind conveying system as standard.
- 9) Dust cyclone separator can effectively remove the air from regrind and facilitates the material collecting.
- 10) Anti-vibration pads absorb vibration from SG-43 series.

Accessory option

- 1) The function of fibre-added material granulating is optional. Adopt surface-hardening treatment on the material contacting component. And blade material is V-4E joint with S50C.
- 2) Cyclone dust separator is available as option for choose and the height of its floor stand can be adjusted on different requirements.
- 3) Two fixed plus five rotating blades is optional with a small feed port of cutting chamber, suitable for granulating block and solid, thick sheet material.
- 4) Separate blower, conveyor and material side feed pipe are optional.

All service work should be carried out by a person with technical training or corresponding professional experience. The manual contains instructions for both handling and servicing. Chapter 6, which contains service instructions intended for service engineers. Other chapters contain instructions for the daily operator.

Any modifications of the machine must be approved by SHINI in order to avoid personal injury and damage to machine. We shall not be liable for any damage caused by unauthorized change of the machine.

Our company provides excellent after-sales service. Should you have any problem during using the machine, please contact the company or the local vendor.

Headquarter and Taipei factory:

Tel: (886) 2 2680 9119

Shini Plastics Technologies (Dongguan), Inc:

Tel: (86) 769 8111 6600

Shini Plastics Technologies India Pvt.Ltd.:

Tel: (91) 250 3021 166

1.3 Technical Specifications

1.3.1 Technical Specifications

Table 1-1: Technical Specifications

Model	SG-4360(H)	SG-4390(H)
Motor Power (kW, 50 / 60Hz)	30 / 34 (37 / 41.5)	37 / 41.5 (45 / 51)
Conveying Blower Power (kW)	2.2 / 2.55	2.2 / 2.55
Rotating Speed (r.p.m 50 / 60Hz)	525 / 630	525 / 630
Number of Fixed Blades	2×1	2×2
Number of Rotating Blades	3×1 (5×1)	3×2 (5×2)
Cutting Chamber (mm)	430×600	430×900
Max. Throughput Capacity (kg/hr)	800	1000
Noise Level dB(A)	105~110	105~110
Material of Blades	SKD11/D2	SKD11/D2
Regrinds Conveyor	✓	✓
Dia. of Screen Hole (Φ12 mm)	✓	✓
Flywheel	✓	✓
Cooling water unit	✓	✓
Dia. of Screen Hole (8,10,17,25 mm)	○	○
Increased Material Conveying Blower Power (kW)	○(3)	○(3)
Dust Separator (DS-43)	○	○
Feeding Chute with Magnet	○	○
Full-receiver Alarm Device	○	○
Belt Conveyor Inlet	○	○
Dimensions		
H (mm)	3155	3155
H1 (mm)	2185	2185
H2 (mm)	1640	1640
H3 (mm)	1630	1630
W(mm)	1450	1750
W1 (mm)	2120	2120
W2 (mm)	480	480
W3(mm)	190	190
D (mm)	1900	1900
D1(mm)	1500	1500
D2(mm)	4200	4250
Net Weight (kg)	2350/2430	2830/2880

Note: 1) "✓" standard, "○" optional.

2) "H" refers to higher motor power.

3) Modified into stainless steel made feed hopper cover plate and storage tank. Add "R" at model behind.

4) SKD11 is material code number of Japanese JIS standard.

5) When the wastes materials with fiber or nearly fiber (CPVC), we can choose granulator with model denotes "F".

6) Max. capacity of the machine is subject to diameter of screen mesh and composition of the material.

7) Noise level will vary with different materials and motor types.

8) Noise level refers to the following conditions: 1 meter around and 1.6 meter above the machine.

9) Power supply: 3Φ, 230 / 400 / 460 / 575VAC, 50 / 60Hz.

1.3.2 Dimensions

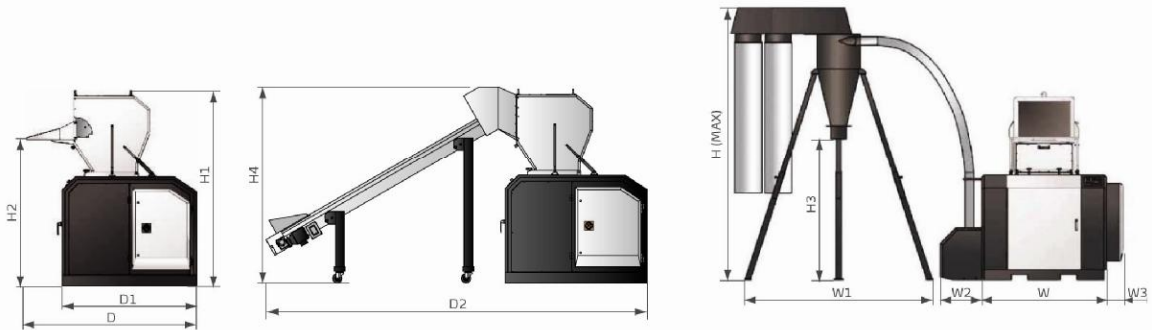

Picture 1-1: Dimensions

1.4 Safety Regulations

Follow the instructions in this manual to avoid personal injury and damage to machine components.

The following safety measures shall be followed when operating the granulator.

1.4.1 Safety Signs and Labels



Electrical installation must only be done by a competent electrician!



Before the granulator is opened for servicing and maintenance, always disconnect the power with both the main switch and the control switch on the granulator.



Never put any part of your body through the granulator openings, unless both the main switch and the control switch on the granulator are in "Off" position.



High voltage! Danger!

This sign is attached on the control box and the wiring box.



Be careful with the rotating knives, they are very sharp and can cause personal injury!



If the rotor must be turned manually-do this with great care!



The granulator should not be able to start before the hopper and screen bracket are properly closed.



Attention please!

Ear protection is used during granulating of plastic materials.



When open feed box, please make sure the front door is opened.



Loading blower is applicable to convey regrind powder and it requires the temperature less than 80°C.



Loading blower has great suction power and it is easy to have objects and clothes suctioned into and lead to personal injuries. So the blower should not be used without any protective cover.



When it is working with transmission belt, please carefully check if the operator's clothes, arm or leg has been stuck by the transmission belt.



Air inlet dust clean.



Concerning SG-43 the cutting chamber should be heat-processed and the blades must be changed before the granulators deal with fibre added material.



Attention!

No need for regular inspection because all the electrical parts in the control unit are fixed tightly!

When operate the granulator, please notice the following signs

	<p style="text-align: center;"> Hazard</p> <p>High voltage! May lead to casualty or other serious danger. Please cut off the power before repairing. Circuit diagram should only be changed by professionals. Grounding is necessary</p>
	<p style="text-align: center;"> Warning</p> <p>Pinch risk when moving belt. Take out or open protective cover is not allowed when it is running.</p>
	<p style="text-align: center;"> Warning</p> <p>There is a pinch risk for this protective cover keep some distance away from that.</p>
	<p style="text-align: center;"> Warning</p> <p>The cutter are very sharp, can cause injury take out or open protective cover is not allowed when it is running keep some distance away from the cutters.</p>
	<p style="text-align: center;"> Notice</p> <p>Read the instruction manual carefully before operating before start, do the safety device test according to the instruction. It is not allowed to change the design of the machine unless it is approved from the manufacture.</p>
<p style="text-align: center; font-size: small;">YP3043000000</p>	<p>Water outlet: drainage outlet.</p>

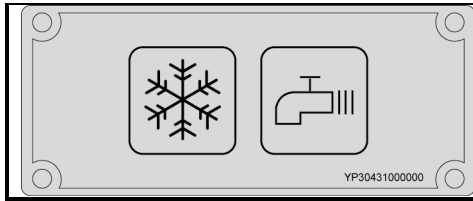

Water inlet: inlet for replenishing water and cooling water.

1.4.2 Transportation and Storage of the Machine

Transportation

- 1) SG-43 series of granulators are packed in plywood cases with wooden pallet at the bottom, suitable for quick positioning by fork lift.
- 2) After unpacked, castors equipped on the machine can be used for ease of movement.
- 3) Do not rotate the machine and avoid collision with other objects during transportation to prevent improper functioning.
- 4) The structure of the machine is well-balanced, although it should also be handled with care when lifting the machine for fear of falling down.
- 5) The machine and its attached parts can be kept at a temperature from -25°C to $+55^{\circ}\text{C}$ for long distance transportation and for a short distance, it can be transported with temperature under $+70^{\circ}\text{C}$.

Storage

- 1) SG-43 series should be stored indoors with temperature kept from 5°C to 40°C and humidity below 80%.
- 2) Disconnect all power supply and turn off main switch and exigency stop switch.
- 3) Keep the whole machine, especially the electrical components away from water to avoid potential troubles caused by the water.
- 4) Use plastic film to cover the machine tightly to prevent the machine from dust and rains.

Working environment

The machine should be operated:

- 1) Indoors in a dry environment with max. temperature +45°C and humidity no more than 80%.

Do not use the machine:



- 1) If it is with a damaged cord.
- 2) On a wet floor or when it is exposed to rain to avoid electric shock.
- 3) If it has been dropped or damaged until it is checked or fixed by a qualified serviceman.
- 4) This equipment works normally in the environment with altitude over 3000m.
- 5) At least 1m surrounding space is requested when this equipment is running. Keep this equipment away from flammable sources at least two meters.
- 6) In the work area of vibration and strong magnetic force.

Rejected parts disposal

When the equipment has run out its life time and can not be used any more, unplug the power supply and dispose of it properly according to local code.



Fire hazard!

In case of fire, CO₂ dry powder fire extinguisher should be applied.



Flammable materials or materials which are contaminated by flammable substances/liquid may not be processed in the granulator. Serious risk of fire or explosion may cause personnel injury.



It is very important to tighten the screw as required torque.



When process item is longer than feed port, please cut long items into half until the length is shorter before processing.



Please don't put materials into the granulator if they are thinner than 2 mm and are soft and flexible, like rubber.

1.5 Exemption Clause

The following statements clarify the responsibilities and regulations born by any buyer or user who purchases products and accessories from Shini (including employees and agents).

Shini is exempted from liability for any costs, fees, claims and losses caused by reasons below:

1. Any careless or man-made installations, operation and maintenances upon machines without referring to the Manual prior to machine using.
2. Any incidents beyond human reasonable controls, which include man-made vicious or deliberate damages or abnormal power, and machine faults caused by irresistible natural disasters including fire, flood, storm and earthquake.
3. Any operational actions that are not authorized by Shini upon machine, including adding or replacing accessories, dismantling, delivering or repairing.
4. Employing consumables or oil media that are not appointed by Shini.

2. Structural Features and Working Principle

2.1 General Description

SG-43 series granulators applicable to granulate waste plastic for recycling use, mount magnet at the material inlet to clean out metal scraps and contaminations before granulating so to prevent metal scraps from getting into cutting chamber and brings damage to the blades.

2.1.1 Working Principle

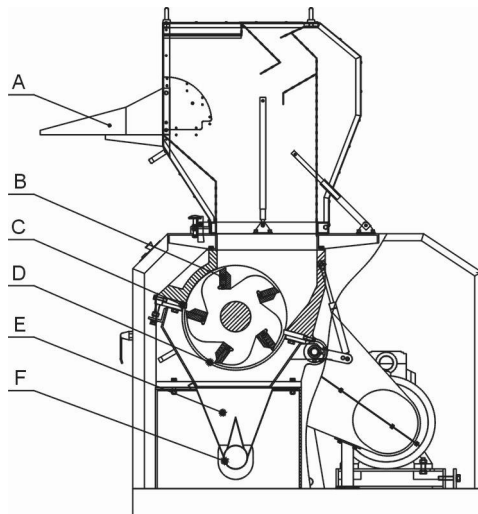

Parts name:

- | | | | |
|-------------------|---------------------|----------------|-----------|
| A. Material inlet | B. Rotating blade | C. Fixed blade | D. Screen |
| E. Storage bin | F. Discharging pipe | | |

Picture 2-1: Working Principle

The waste materials enter the cutting chamber via material inlet (A). The rotating blade (B) and fixed blade (C) grind the materials. The particle size is controlled by the size of screen (D). The screen (D) is located behind of the granulation chamber. Thus it is convenient to replace screen for other different sizes. The granulated materials are dropped into the regrind storage bin (E) via the screen and be conveyed via discharging pipe (F).

The external material-conveying blower absorbs the granulated materials into the cyclone dust separator to separate the granulated materials and air.

The obtained particles can be reused directly or sent to somewhere for storage. The foldable feed box has a good tunnel for maintenance, thus it is very convenient for cleaning.

2.2 Safety System

The granulator possesses a highly-secure safety system to avoid accident during the operation. The fast-rotating blade in the granulator is prone to result in an accident.

Thus, the safety system can protect human body. The safety system can be altered under no circumstances, otherwise the machine would in dangerous situation and can do harms. All repair and maintenance work should be carried out by the professionals.

If any safety system change takes place, no commitment will be fulfilled and all replaced components should be provided by SHINI.

2.2.1 Emergency Stop

Emergency stop is a red button on the control panel. Press it then the machine will stop working. Turn the button in the arrow direction (anticlockwise) we can reset it.



Emergency Stop

Picture 2-2: Emergency Stop

2.2.2 Safety Switch

There are safe position switches for circuit breakers in the granulator. If there is any change, for example, the position of the door or the feed box changed or the circuit breaker is loose, the safety position switch will cut the power off and stop the machine.

Two safety switches may be involved. One is located between the feed box and the cutting chamber and the other links to the lock in the machine door.

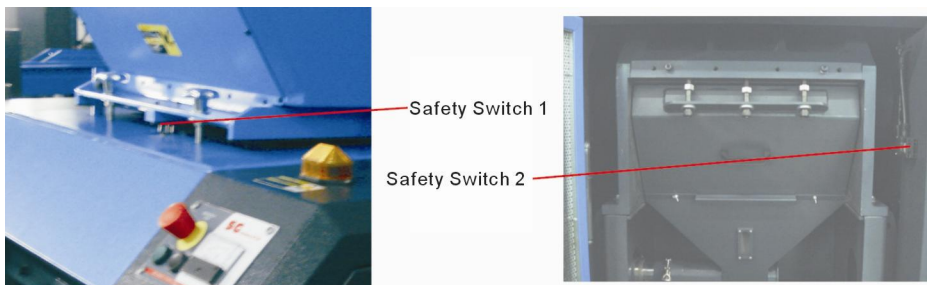

Picture 2-3: Safety Switch

2.2.3 Long Star Screw

When opening the door, this hexagonal screw shall be loosened. Loosening the door-lock needs a period of time avoiding personnel injury.

Keep in mind before you start the granulator:

- 1) Whether the feed box has been tightly locked or not.
- 2) Whether the screen or the regrind storage bin has been well installed or not.
- 3) Close the door.



Picture 2-4: Screw Shaft

2.3 Assembly Drawing

2.3.1 Assembly Drawing

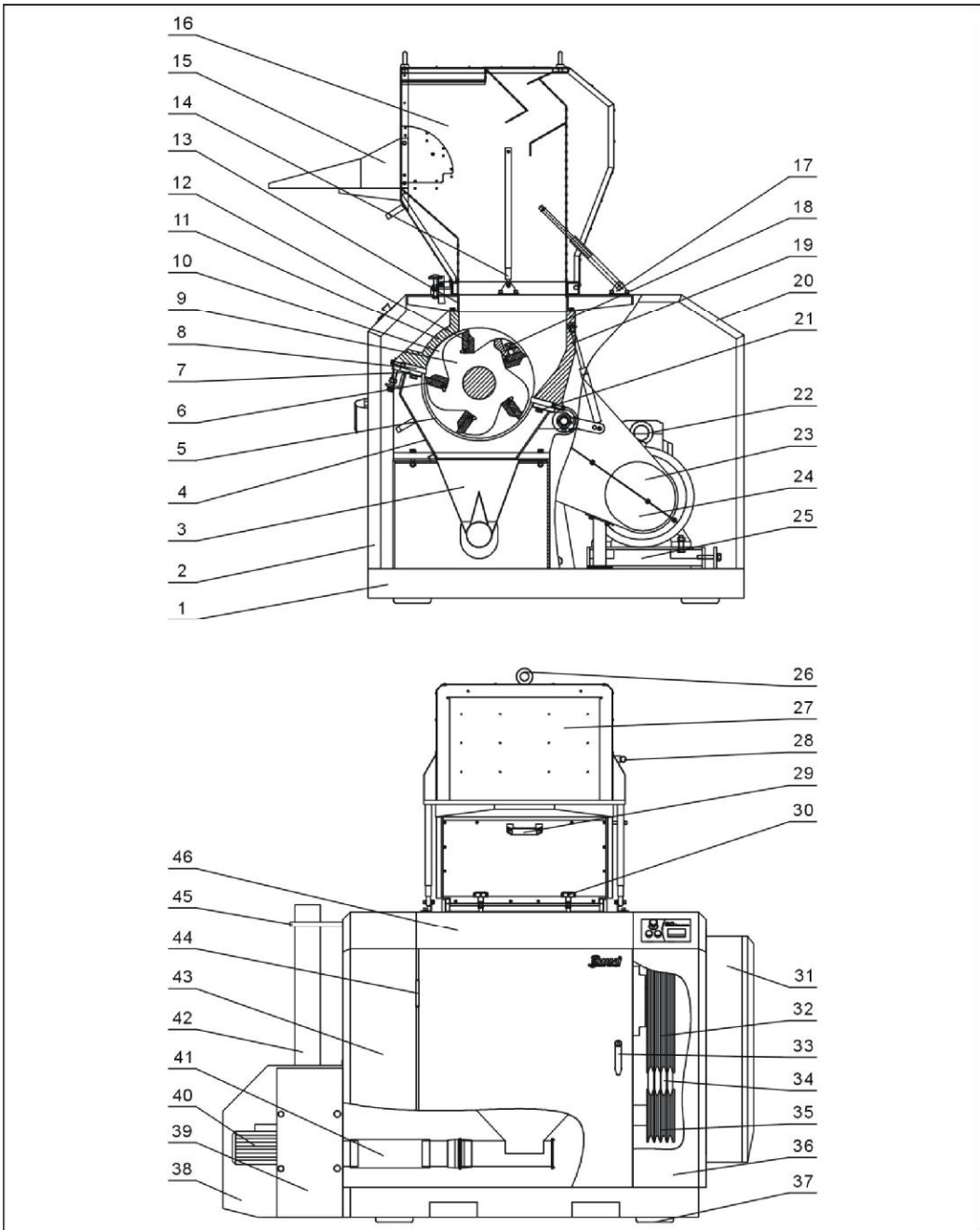

Note: Please refer to 2.3.2 material list about the parts code.

Picture 2-5: Assembly Drawing

2.3.2 Parts List

Table 2-1: Parts List

No.	Name	Part No.	
		SG-4360(H)	SG-4390(H)
1	Base	-	-
2	Door plank	-	-
3	Regrind storage bin	-	-
4	Screen bracket	-	-
5	Screen (Φ8)**	BL55436000820	-
	Screen (Φ10)**	BL55436000220	-
	Screen (Φ12)**	BL55436200220	BL55439001320
	Screen (Φ17)**	-	-
	Screen (Φ25)**	-	-
6	Rotating blade**	BH10436300110	BW40439001410
7	Fixed knife briquetting	BH11436000310	BH11439000310
8	Fixed blade**	YW42436000400	BW40439000410
9	Blade rest	BH11436001010	BH11439000710
10	Material fender	YW42436001600	YW42436001600
11	Front box block	BW30436000510	BW30439000510
12	Pressure block	BH11506000610	BH11439001310
13	Cutting chamber	-	-
14	Pneumatic spring 600N	YW01060000000	YW01060000000
15	Feeding inlet	-	-
16	Feeding hopper	-	-
17	Support base	-	-
18	Inner hexagonal screw column M20X65	YW61206500000	YW61206500000
19	Back box block	BW30436000710	BW30439001410
20	Back cover board	-	-
21	Fixed blade press block	YW61167500000	YW61167500000
22	Electromotor	YM10420700200	YM10422000100
		YM10422000100	YM10422300000
23	Protective hood	-	-
24	Protective hood	-	-
25	Installation base	-	-
26	Screw M16	YW09001600000	YW09001600000
27	Material fender	-	-
28	Protective hood	YW30003600100	YW30003600100
29	Knob *	BW20012000140	BW20012000140
30	Screw shaft	BH56240200010	BH56240200010

No.	Name	Part No.	
		SG-4360(H)	SG-4390(H)
31	Electrical control box *	BH59436000050	BH59436800150
32	Big belt pulley	YW30560400000	YW30205600000
33	Door lock	YW00004500000	YW00307200000
34	V belt SPC-2800*	YR00280000000	YR00280000000
35	Belt pulley	YW30200400000	YW30200600000
36	Right cover board	-	-
37	Anti vibration pad M16X147	YW03162000000	YW03162000000
38	Cover	-	-
39	Blower supporter	-	-
40	Blower *	BM30224000050	BM30224000050
41	Feeding pipe	YR60000400100	YR60000400100
42	Blower flange	BH10436002110	BH10436002110
43	Left cover board	-	-
44	Hinge	YW06000400000	YW06000400000
45	Fixed block	BH10436002010	BH10436002010
46	Front top board	-	-

* means possible broken parts.

** means easy broken part. and spare backup is suggested.

Please confirm the version of manual before placing the purchase order to guarantee that the item number of the spare part is in accordance with the real object.

2.3.3 Cutting Chamber

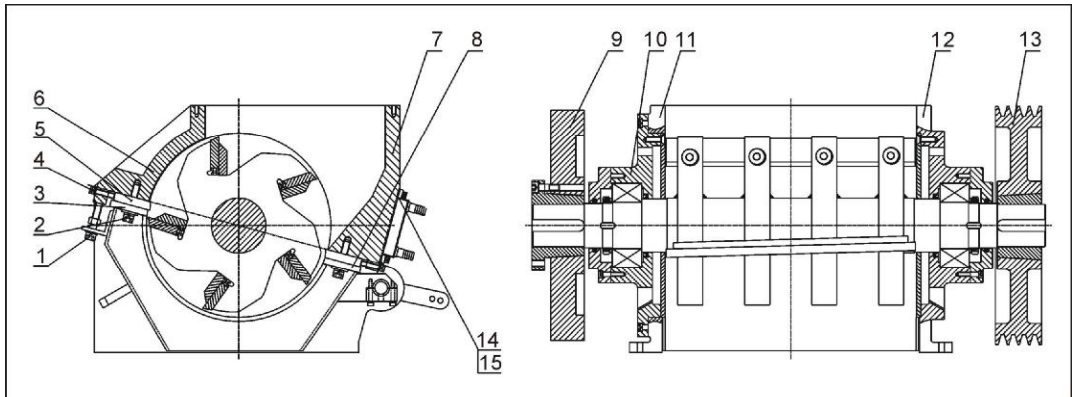

Picture 2-6: Cutting Chamber

2.3.4 Cutting Chamber Parts List

Table 2-2: Cutting Chamber Parts List

No.	Name	Quantity
1	Hexagon socket cap screw M16 × 100	3
2	Hexagon socket cap screw M16 × 75	10
3	Front pressing block	1
4	Hexagon socket cap screw M10 × 70	4
5	Fixed blade	2
6	Front box block	1
7	Back box block	1
8	Back pressing block	1
9	Taper sleeve	1
10	Bearing block	1
11	Left insert block	1
12	Right insert block	1
13	Big belt pulley	1
14	Water tank	1
15	Water tank washer	1

2.3.5 Blade Rest

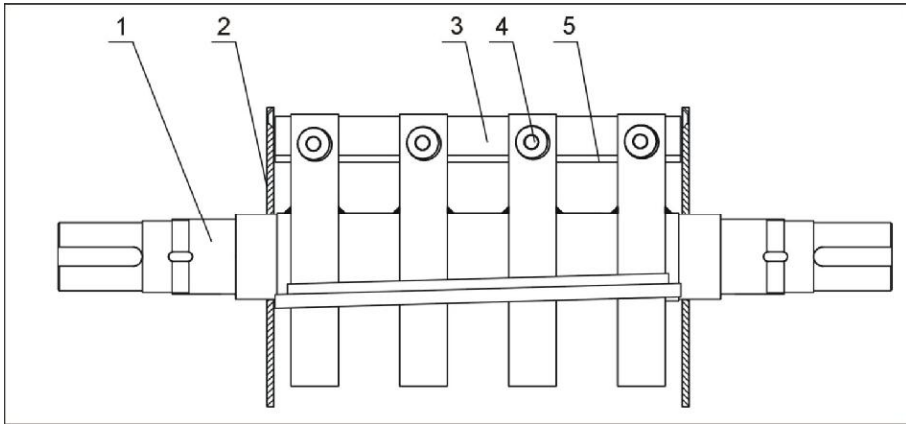

Picture 2-7: Blade Rest

2.3.5.1 Blade Rest Parts List

Table 2-3: Blade Rest Parts List

No.	Name	Quantity
1	Cutter shaft	1
2	Material fender	2
3	Blade rest	5/10
4	Inner hexagon cylindrical screw	20/40
5	Blade rest press plate	510

2.3.6 Transmission Parts

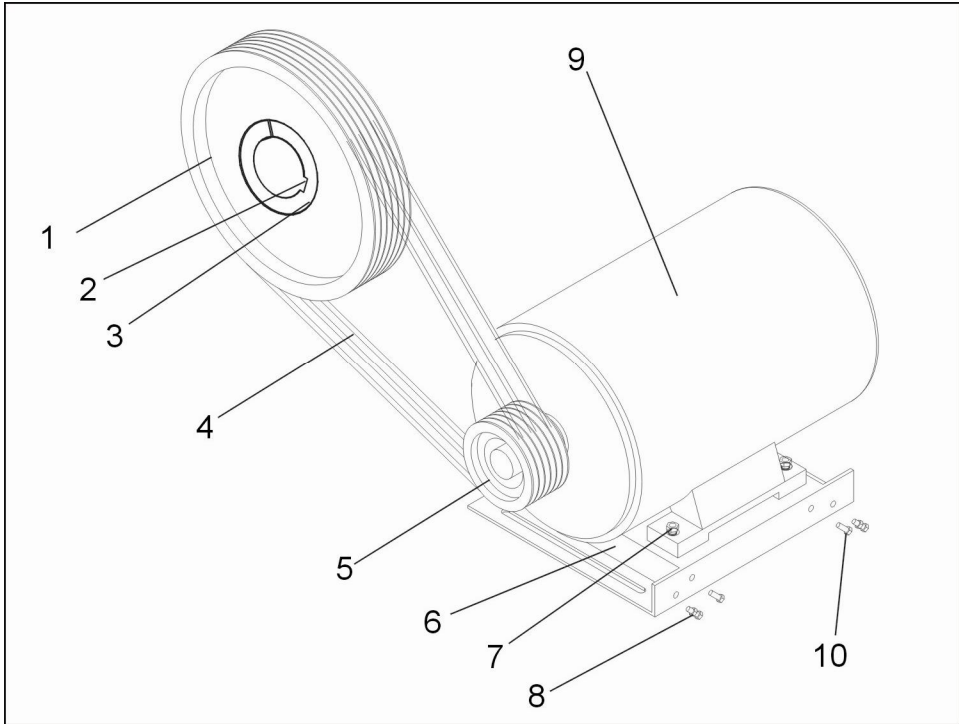

Picture 2-8: Transmission Parts

2.3.7 Transmission Parts Parts List

Table 2-4: Transmission Parts Parts List

No.	Name	Quantity
1	Driven wheel	1
2	Key	1
3	Lockup cover	1
4	V belt (SPC)	4
5	Driving wheel	1
6	Electromotor base	1
7	Electromotor screw	4
8	Nut	2
9	Electromotor	1
10	Adjusting screw	2

2.3.8 Screen

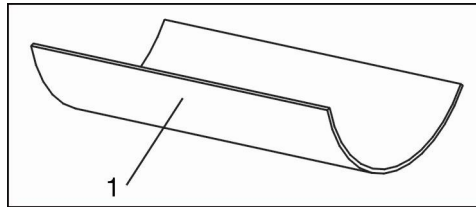

Picture 2-9: Screen

2.3.9 Screen Parts List

Table 2-5: Screen Parts List

No.	Name	Quantity
1	Screen	1

2.3.10 Screen Bracket

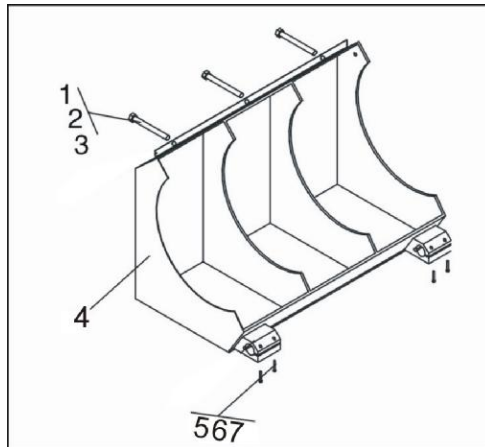

Picture 2-10: Screen Bracket

2.3.11 Screen Bracket Parts List

Table 2-6: Screen Bracket Parts List

No.	Name	Quantity	No.	Name	Quantity
1	Bolt	3	5	Bolt	4
2	Spring gasket	3	6	Spring gasket	4
3	Flat gasket	3	7	Flat gasket	4
4	Screen bracket	1			

2.3.12 Blower

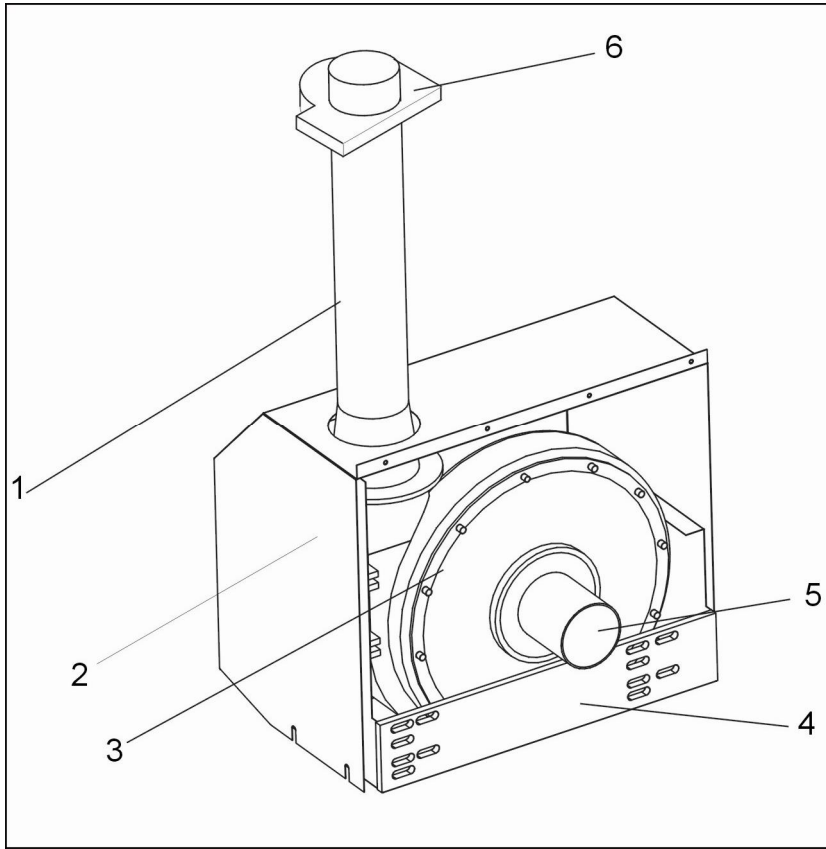

Picture 2-11: Blower

2.3.13 Blower Parts List

Table 2-7: Blower Parts List

No.	Name	Quantity
1	Outlet pipe	1
2	Cover	1
3	Blower	1
4	Bottom plate	1
5	Air inlet	1
6	Coupling clip	1

2.3.14 Feed Box, Insulative Box and Shutter

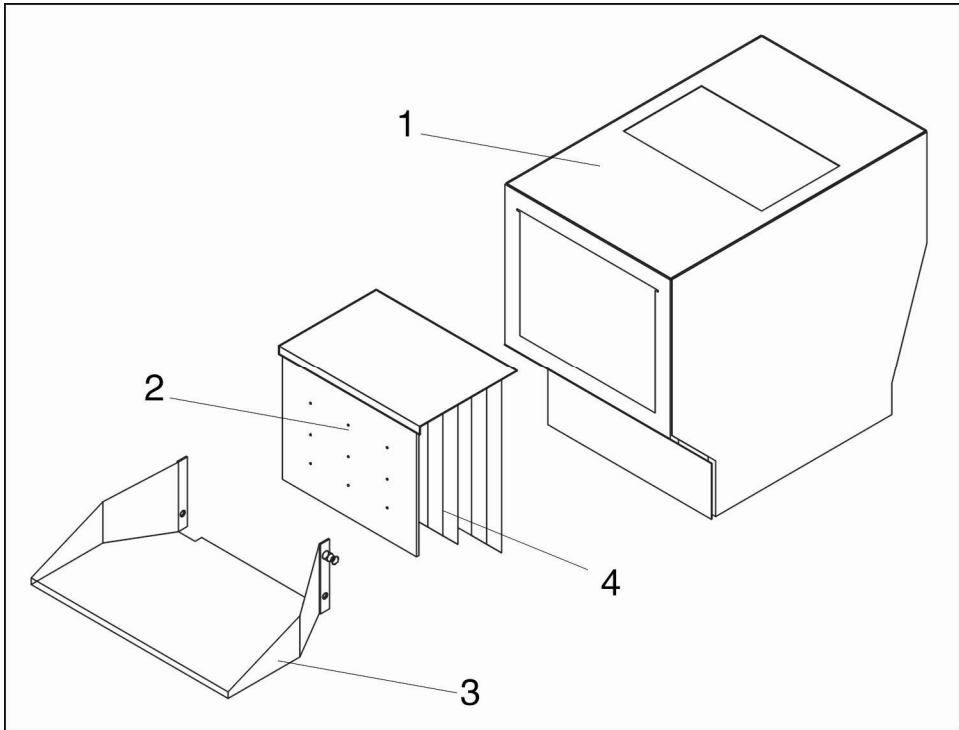

Picture 2-12: Feed Box, Insulative Box and Shutter

2.3.15 Feed Box, Insulative Box and Shutter Parts List

Table 2-8: Feed Box, Insulative Box and Shutter Parts List

No.	Name	Quantity
1	Feed box	1
2	Materials shutter	1
3	Feeding inlet	1
4	Materials keeping leather	2

2.3.16 Re grind Storage Bin

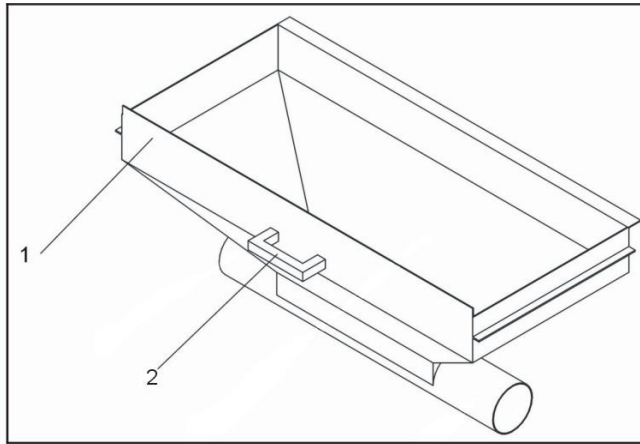

Picture 2-13: Re grind Storage Bin

2.3.17 Re grind Storage Bin Parts List

Table 2-9: Re grind Storage Bin Parts List

No.	Name	Quantity
1	Storage box	2
2	Knob	1

2.4 Wiring Diagram

2.4.1 Main Circuit

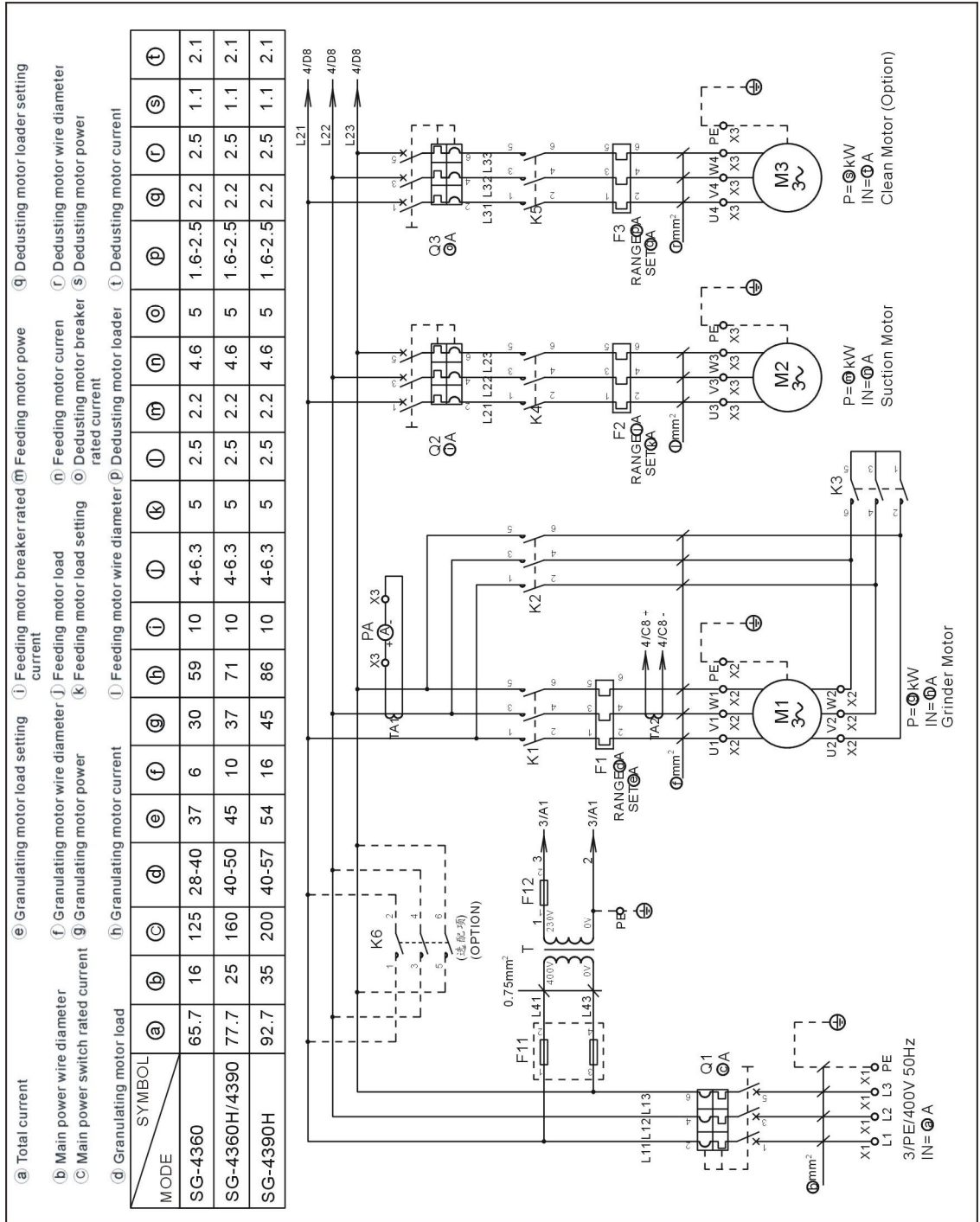

Picture 2-14: Main Circuit

2.4.2 Control Wiring Diagram

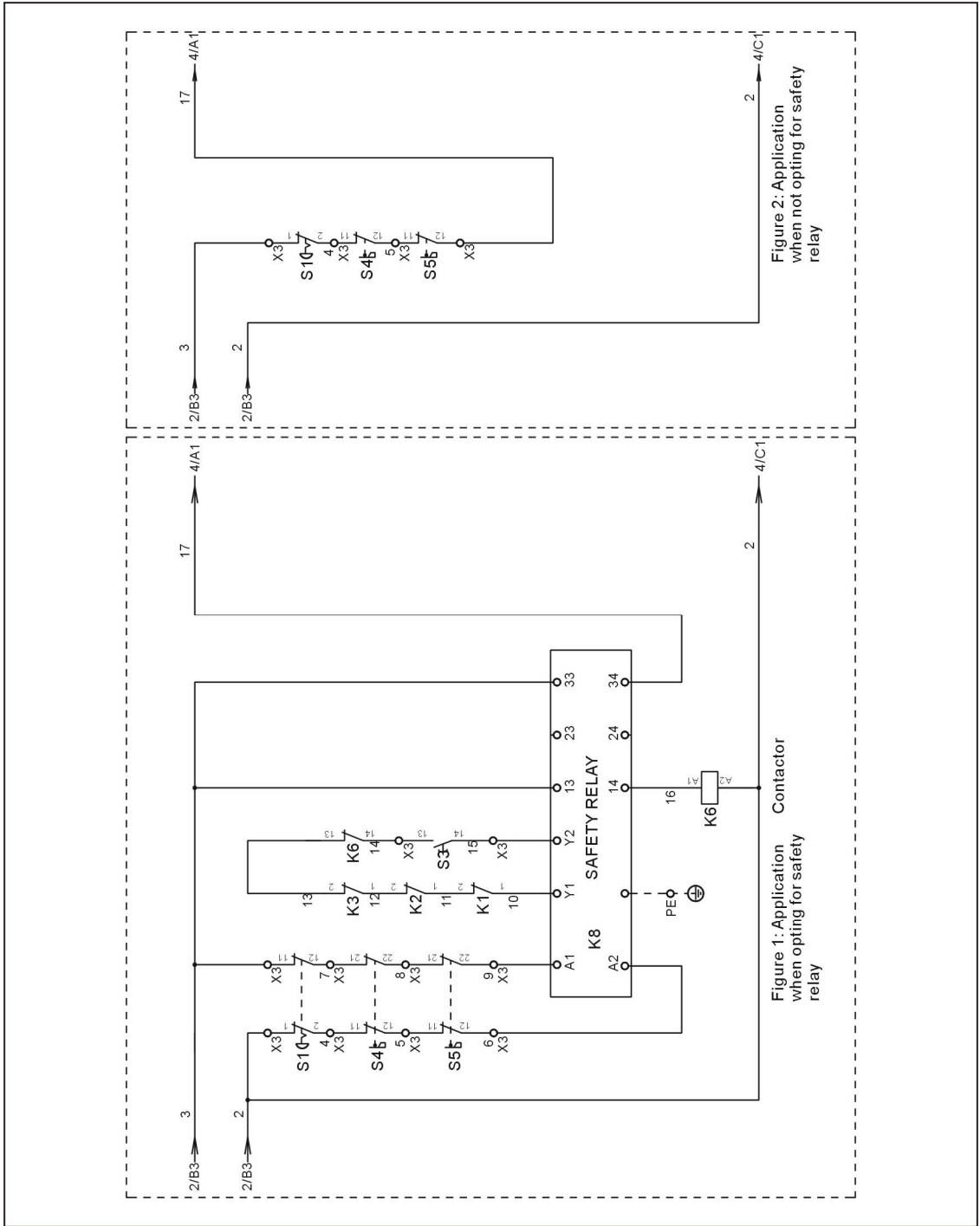

Picture 2-15: Control Wiring Diagram 1

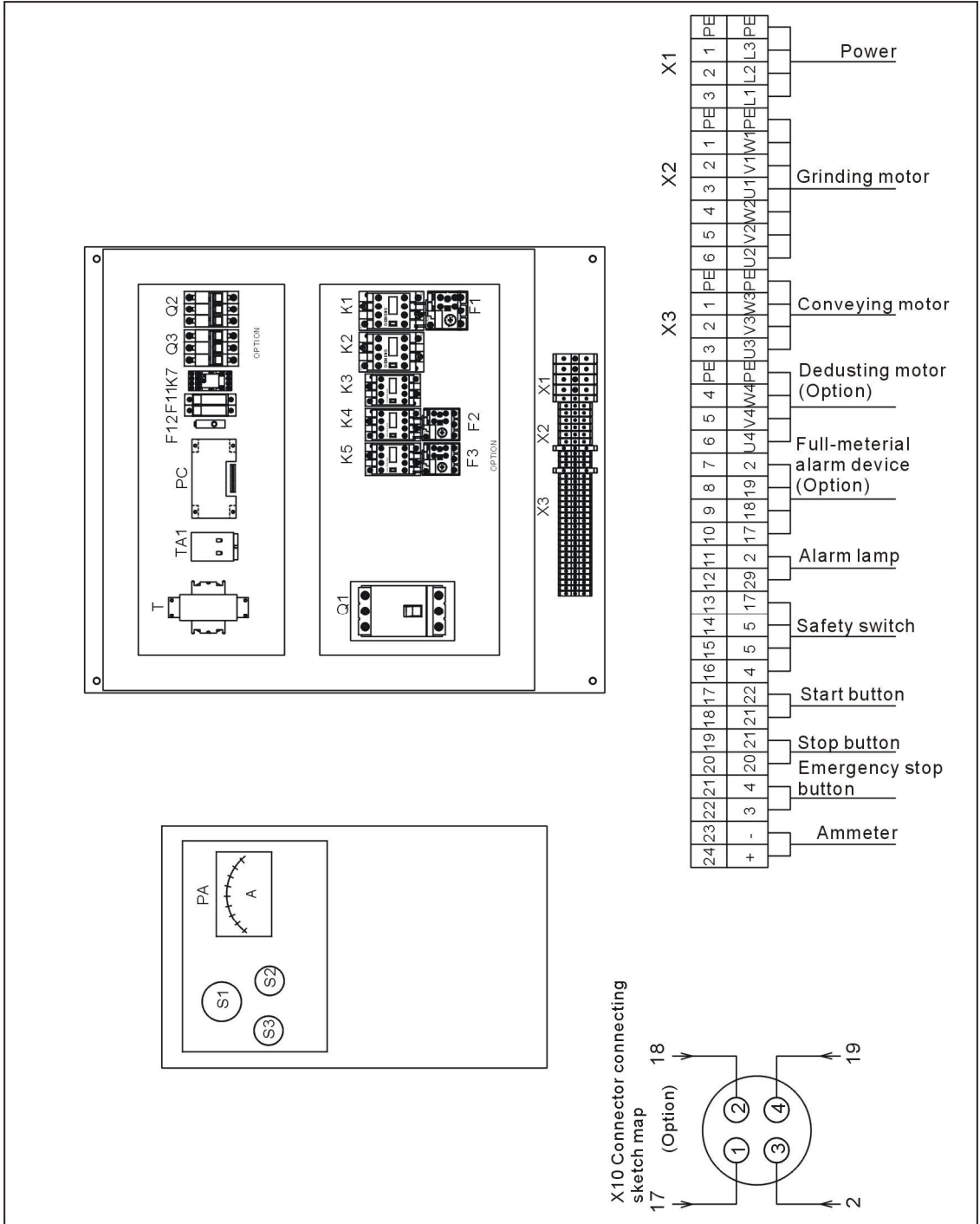

Picture 2-18: Electrical Components Layout (Not Opt for Safety Relay)

2.4.4 Electrical Components List

Table 2-10: SG-4360 Electrical Components List

NO.	Symbol	Name	Specification	Part NO.
1	Q1	Gete circuit breaker*	125A	YE41161200000
2	Q2	Circuit breaker	10A	YE40600300000
3	Q3	Circuit breaker	5A	YE40603000000
4	K1 K2	Contacto**	220V 50/60Hz	YE00503500000
5	-	Auxiliary contactor	1NC	YE00592110100
6	-	Auxiliary contactor	1NC	YE00592110100
7	K3	Contacto**	230V 50/60Hz	YE00602722000
8	-	Auxiliary contactor	1NO+1NC	YE00691100100
9	K4	Contacto**	220V 50/60Hz	YE00601521000
10	-	Auxiliary contactor	1NO	YE00691110000
11	K5	Contacto**	220V 50/60Hz	YE00601521000
12	K6	Contacto**	230V 50/60Hz	YE00504400000
13	-	Auxiliary contactor	1NC	YE00592110100
14	K7	Over circuit realy	220VAC	YE03270700000
15	K8	Safety realy	230AC 50/60Hz	YE04372100000
16	F1	Overload relay**	28~40A	YE01513600100
17	F2	Overload relay**	4.5~6.3A	YE01160450000
18	F3	Overload relay**	1.8~2.5A	YE01160180000
19	F11	Fuse**	2P	YE41032200000
20	-	Fuse core**	1A	YE46001000100
21	F12	Fuse**	2A	YE41001000000
22	S1	Emergency stop button**	1NC	YE11411000000
23	-	Contact block	1NC	YE19001000100
24	S2	Stop button*	1NC	YE11113100000
25	S3 H1	Start button*	1NO	YE11100100000
26	S3 H1	Start button*	2NO	YE11142100000
27	S4 S5	Safety switch*	230VAC	YE16147600000
28	H2	Alarm lamp	230VAC 50/60Hz	YE83305100200
29	H3	Buzzer	230VAC	YE84222000000
30	MS	Feed position	3A/250VAC	YE15000200100
31	T	Transformer*	IN=400V OUT=230V 500mA	YE70402300800
32	TA1	Current mutual inductance	100/5A	YE04100500000
33	PA	Galvanmetry	100/5A	YE25671000000
34	X1	Terminal board	16mm ²	YE61160000000
35	-	-	16mm ² PE	YE61163500000

NO.	Symbol	Name	Specification	Part NO.
36	X2	Terminal board	6mm ²	YE61060000000
37	-	-	6mm ² PE	YE61063500000
38	X3	Terminal board	2.5mm ²	YE61250040000
39	-	-	2.5mm ² PE	YE61253500000
40	-	-	2.5mm ²	YE61250040000
41	-	-	2.5mm ² PE	YE61253500000
42	-	-	2.5mm ²	YE61250040000
43	-	-	2.5mm ²	YE61250040000
44	X10	Metal tie in	4P	YE68025400000
45	-	-	4P	YE68025400100
46	PCB	PCB	220VAC	YE80022200100
47	TA2	Current mutual inductance	5~100A	-
48	M1	Granulating motor	400V 50Hz 30kW	-
49	M2	Solution blower	400V 50Hz 2.2kW	-
50	M3	Dust blower	400V 50Hz 1.1kW	-

* means possible broken parts.

** means easy broken part. and spare backup is suggested.

Please confirm the version of manual before placing the purchase order to guarantee that the item number of the spare part is in accordance with the real object.

Table 2-11: SG-4360H/4390 Electrical Components List

NO.	Symbol	Name	Specification	Part NO.
1	Q1	Gete circuit breaker*	160A	YE41161600000
2	Q2	Circuit breaker	10A	YE40600300000
3	Q3	Circuit breaker	5A	YE40603000000
4	K1 K2	Contactor**	220V 50/60Hz	YE00503600000
5	K3	Contactor**	220V 50/60Hz	YE00503500000
6	-	Auxiliary contactor	1NC	YE00592110100
7	-	Auxiliary contactor	1NC	YE00592110100
8	K4	Contactor**	220V 50/60Hz	YE00601521000
9	-	Auxiliary contactor	1NO	YE00691110000
10	K5	Contactor**	220V 50/60Hz	YE00601521000
11	K6	Contactor**	230V 50/60Hz	YE00504500000
12	-	Auxiliary contactor	1NC	YE00592110100
13	K7	Over circuit realy	220VAC	YE03270700000
14	K8	Safety realy	230AC 50/60Hz	YE04372100000
15	F1	Overload relay**	40~50A	YE01513600900
16	F2	Overload relay**	4.5~6.3A	YE01160450000
17	F3	Overload relay**	1.8~2.5A	YE01160180000
18	F11	Fuse**	2P	YE41032200000
19	-	Fuse core**	1A	YE46001000100
20	F12	Fuse**	2A	YE41001000000
21	S1	Emergency stop button**	1NC	YE11411000000
22	-	Contact block	1NC	YE19001000100
23	S2	Stop button*	1NC	YE111113100000
24	S3 H1	Start button*	1NO	YE11100100000
25	S3 H1	Start button*	2NO	YE11142100000
26	S4 S5	Safety switch*	230VAC	YE16147600000
27	H2	Alarm lamp	230VAC 50/60Hz	YE83305100200
28	H3	Buzzer	230VAC	YE84222000000
29	MS	Feed position	3A/250VAC	YE15000200100
30	T	Transformer*	IN=400V OUT=230V 500mA	YE70402300800
31	TA1	Current mutual inductance	100/5A	YE04100500000
32	PA	Galvanmetry	100/5A	YE25671000000
33	PCB	PCB	220VAC	YE80022200100
34	TA2	Current mutual inductance	5~100A	-
35	X1	Terminal board	-	YE61160000000
36	-	-	-	YE61163500000
37	X2	Terminal board	76A	YE61025000100

NO.	Symbol	Name	Specification	Part NO.
38	-	-	-	YE61063500000
39	X3	Terminal board	2.5mm ²	YE61250040000
40	-	-	2.5mm ² PE	YE61253500000
41	-	-	2.5mm ²	YE61250040000
42	-	-	2.5mm ² PE	YE61253500000
43	-	-	2.5mm ²	YE61250040000
44	-	-	2.5mm ²	YE61250040000
45	X10	Metal tie in	4P	YE68025400000
46	-	-	4P	YE68025400100
47	M1	Granulating motor	400V 50Hz 37kW	-
48	M2	Solution blower	400V 50Hz 2.2kW	-
49	M3	Dust blower	400V 50Hz 1.1kW	-

* means possible broken parts.

** means easy broken part. and spare backup is suggested.

Please confirm the version of manual before placing the purchase order to guarantee that the item number of the spare part is in accordance with the real object.

Table 2-12: SG-4390H Electrical Components List

NO.	Symbol	Name	Specification	Part NO.
1	Q1	Gete circuit breaker*	200A	YE41252000000
2	Q2	Circuit breaker	10A	YE40600300000
3	Q3	Circuit breaker	5A	YE40603000000
4	K1 K2	Contacto**	220V 50/60Hz	YE00504400000
5	K3	Contacto**	220V 50/60Hz	YE00503600000
6	-	Auxiliary contactor	1NC	YE00592110100
7	-	Auxiliary contactor	1NC	YE00592110100
8	K4	Contacto**	220V 50/60Hz	YE00601521000
9	-	Auxiliary contactor	1NO	YE00691110000
10	K5	Contacto**	220V 50/60Hz	YE00601521000
11	K6	Contacto**	220V 50/60Hz	YE00504600000
12	-	Auxiliary contactor	1NC	YE00592110100
13	K7	Over circuit realy	220VAC	YE03270700000
14	K8	Safety realy	230AC 50/60Hz	YE04372100000
15	F1	Overload relay**	45~63A	YE01514640000
16	F2	Overload relay**	4.5~6.3A	YE01160450000
17	F3	Overload relay**	1.8~2.5A	YE01160180000
18	F11	Fuse**	2P	YE41032200000
19	-	Fuse core**	1A	YE46001000100
20	F12	Fuse**	2A	YE41001000000
21	S1	Emergency stop button**	1NC	YE11411000000
22	-	Contact block	1NC	YE19001000100
23	S2	Stop button*	1NC	YE11113100000
24	S3 H1	Start button*	1NO	YE11100100000
25	S3 H1	Start button*	2NO	YE11142100000
26	S4 S5	Safety switch*	230VAC	YE16147600000
27	H2	Alarm lamp	230VAC 50/60Hz	YE83305100200
28	H3	Buzzer	230VAC	YE84222000000
29	MS	Feed position	3A/250VAC	YE15000200100
30	T	Transformer*	IN=400V OUT=230V 500mA	YE70402300800
31	TA1	Current mutual inductance	150/5A	YE04150500000
32	PA	Galvanmetry	150/5A	YE25671500000
33	PCB	PCB	220VAC	YE80022200100
34	TA2	Current mutual inductance	5~100A	-
35	X1	Terminal board	-	YE61350040000
36	-	-	-	YE61353500000
37	X2	Terminal board	-	YE61160000000

NO.	Symbol	Name	Specification	Part NO.
38	-	-	-	YE61163500000
39	X3	Terminal board	2.5mm ²	YE61250040000
40	-	-	2.5mm ² PE	YE61253500000
41	-	-	2.5mm ²	YE61250040000
42	-	-	2.5mm ² PE	YE61253500000
43	-	-	2.5mm ²	YE61250040000
44	-	-	2.5mm ²	YE61250040000
45	X10	Metal tie in	4P	YE68025400000
46	-	-	4P	YE68025400100
47	M1	Granulating motor	400V 50Hz 45kW	-
48	M2	Solution blower	400V 50Hz 2.2kW	-
49	M3	Dust blower	400V 50Hz 1.1kW	-

* means possible broken parts.

** means easy broken part. and spare backup is suggested.

Please confirm the version of manual before placing the purchase order to guarantee that the item number of the spare part is in accordance with the real object.

2.5 Electrical Components Instruction

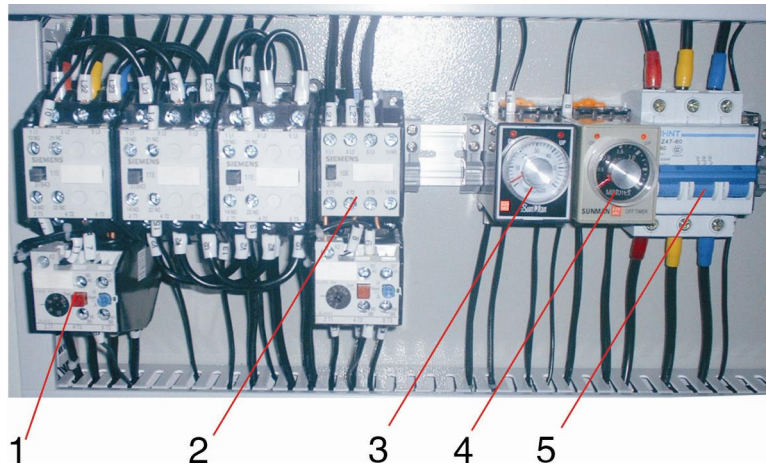

Picture 2-19: Electrical Components Instruction

1. Thermo overload relay, which can protect the motor when it is overloading or open phase.
2. Electromagnetic contactor, which can connect or cut off the circuit from remote.
3. Electrify delay relay, which can control motor to start from Y to Δ with a voltage lower down, by doing this to save the startup current.
4. Power cut off delay relay, which can delay the blower's stop time, and when stop the machine, it can make the machine do a little extra work to suction the material at the bottom of the tube or within the storage box.
5. Circuit breaker which performs the function of overloading protection and short circuit protection.

2.6 Optional Accessories

2.6.1 DS-43 Dust separate System

2.6.1.1 Installation Illustrative Photo

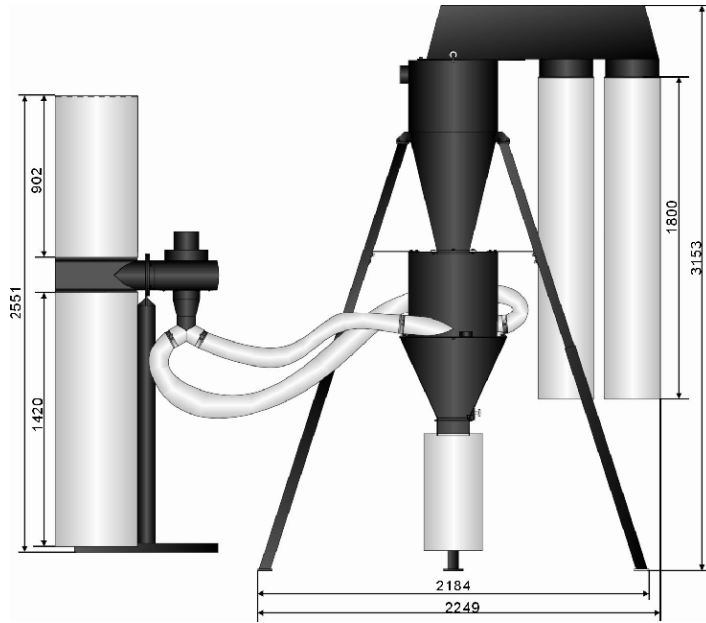

Picture 2-20: Installation Illustrative Photo

Table 2-13: Parts list of Installation Illustrative

Fittings	Quantity	Note	Fittings	Quantity	Note
Cyclone separator	1 piece		Filtering hop-pocket	2 piece	
Dust separator	1 piece		Dust collection hop-pocket	2 piece	With cotton
Wind machine housing	1 piece		Fixing bracket for cyclone dust separator	Upper 3 items Lower 3 items	
Stainless steel pipe (long one)	1 piece		Doth bag bracket	1 piece	
Pipe Clip 5"	6 piece		Multi-thread plastic pipe 4"×3m	3 piece	
Hop-pocket (two ends are opening)	1 piece	With cotton	Locking fittings	2 piece	

2.6.1.2 Installation



Read chapter 3 carefully before operating on dust separate system the circuit connection of the system should be done by professional electrician.

Before first startup

The unpainted parts of the machine are protected with oil prior to delivery and transport. Clean the granulator from rust protection agent before it is used.

Connection

- 1) Place a separator under cyclone device, the diameter is $\Phi 250\text{mm}$.
- 2) Connect to conveying pipe, the diameter is 4 inches \times 2.
- 3) Mount dust collection device including air and dust separate bags.
- 4) Place a container under the separator to help collecting plastic material after dustremoving.



Notes!

If use cloth bag to connect the separator, please make sure a good ventilation within the cloth bag.

2.6.1.3 Operation and Maintenance

Start and stop of the machine.

Start and stop of the machine is controlled by main power switch.

2.6.1.4 Check

Daily check

Air and dust bags, check if these bags are damaged, if there is any damage, please replace them.

Check if the conveying pipe is damaged, if it is, please replace it.

Check if the connecting joint had been fixed and sealed.

Check if the dust collection bag is full, if it is, please dump it check if the collection barrel is placed right under the dust separator, if there has any deviation, please adjust it.

Check the collection barrel, if it is full, take out the dust removed plastic in time.

Weekly check

Check to see if the wire has any damage and the condition of the wire, if it has any problem, please fix it.

2.6.2 Clean



Notes!

Clean the machine when the processing material is changed or after every 300-hour running time. Before cleaning, please cut off the power.

- 1) First clean the inner side of the cleaning facilitates.
- 2) It is necessary to check and clean dust separator.
- 3) Move away separator, use high pressure air to blow away its interior granules.
- 4) Clean out the storage hopper and clean its interior.
- 5) Shake the air bag to drop the dust down.
- 6) Assembly the disassembled parts according to reversed order.

2.6.3 Screen



Picture 2-21: Screen

2.6.4 Cutters

Material	International code		
	China GB	USA ASTM	Japan JIC
SKD11	Cr12MoV	D2	SKD11

3. Installation and Debugging



Read through this chapter before installation.



Install as following orders to avoid any accident!



Be careful! Not to be cut by the sharp blade.



Power connection must be done by the professional electrician to avoid electrical shock.



Caution!

cutters should be laid level, prevent the cutters from self-rotating when do installation, don't let your hands be near to the cutters to avoid personal injury.



Notice!

Do not install the cutters by working together, because this could bring personal injury. Use a thick wood block to stop the rotating knives from turning.



Notice!

The blades are very sharp, so use protective gloves to avoid being cut.



Notice!

Please use new screws and gaskets when installing cutters.



The power connection of the granulator should be carried out by professional electrician so to avoid electrical shock!

Table 3-1: Attached Form, Cutters and Other Fixing Screw Torque

Threading Type	Threading Specification	Stretching Force FV (N)			Tightening Torque Ma (N.m)		
		Grade -8.8	Grade -10.9	Grade -12.9	Grade -8.8	Grade -10.9	Grade -12.9
Coarse Thread	M4	3900	5750	6700	3.0	4.4	5.1
	M5	6400	9400	11000	5.9	8.7	10
	M6	9000	1320	15500	10	16	18
	M8	16500	24300	28400	25	36	43
	M10	26300	38700	45200	49	72	84
	M12	38400	56500	66000	86	126	145
	M14	62500	77500	90500	135	200	236
	M16	72500	10700	12500	210	310	365
	M18	91000	129000	152000	300	430	600
	M20	117000	166000	195000	425	610	710
	M22	146000	208000	244000	580	820	960
	M24	168000	240000	281000	730	1050	1220
	M27	222000	316000	369000	1100	1550	1800
	M30	269000	384000	449000	1450	2100	2450
Fine Thread	M8×1	18100	26600	31200	27	39	46
	M10×1.25	28300	41600	48700	52	76	90
	M12×1.25	43300	63500	74600	93	135	160
	M12×1.5	40800	60000	70000	89	130	155
	M14×1.5	58600	86000	100000	145	215	255
	M16×1.5	79500	116000	136000	226	330	390
	M18×1.5	108000	152000	177000	340	485	570
	M20×1.5	134000	191000	224000	475	680	790
	M22×1.5	166000	236000	276000	630	900	1050
	M24×2	189000	270000	316000	800	1150	1350
	M27×2	246000	350000	409000	1150	1650	1950
	M30×2	309000	440000	515000	1650	2350	2750

3.1 Installation Notice

- 1) Make sure voltage and frequency of the power source comply with those indicated on the manufacture's plate, which is attached to the machine.
- 2) Power cable and earth connections should conform with local regulations.
- 3) Use independent power cable and ON / OFF switch. The cable's dia. Should not smaller than those applied in the control box.
- 4) The power cable connection terminals should be tightened securely.
- 5) The machine requires a 3-phase 4-wire power source, connect the power lead (L1, L2, L3) to the live wires, and the earth (PE) to the ground.
- 6) Power supply requirements:
Main power voltage: +/- 10%
Main power frequency: +/- 2%

Make at least 1 meter clearance around the machine to facilitate repair and maintenance.

3.2 Installation Place



Make enough installation space to help the repair and maintenance. Check and make sure the installation ground is level, there is enough intensity when it is running.

Use spirit level to adjust the cutting chamber to the level position.

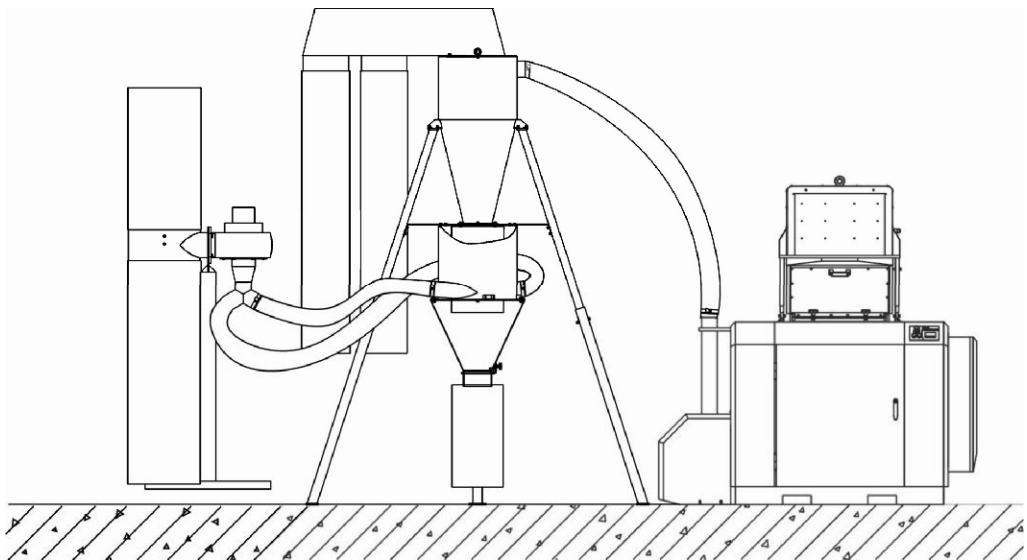

Picture 3-1: Installation Place 1

SG-43 rabbets for forklift to transport.

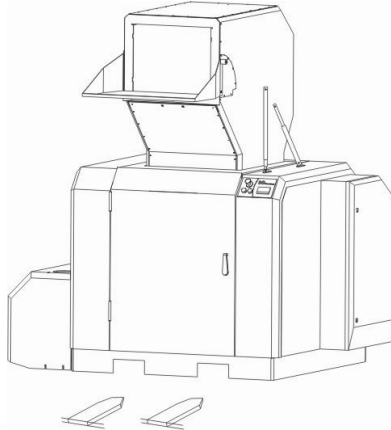

Picture 3-2: Installation Place 2



Please do not install feed box on the mainbody of the granulator, then hoist them together, or it will cause damage to the machine.

3.3 Installation of Bearing and Blade Rest

- 1) Lock up the left, right, front and back block of cutting chamber by screw, then install right side of material feeder.
- 2) Put the blade rest inside the bearing block.
- 3) Put the material feeder and left bearing block into the bearing of blade rest, and lock them tightly on the left side of block of cutting chamber.
- 4) Install the shutter ring and bearing cap. Then, lock it up with screws.



Note!

Add some lubricating oil in both bearing and bearing block.

- 5) Check the gap between left and right blade rest, finally install bearing cover and lock it up, avoid axial movement of right bearing.



Picture 3-3: Installation of Bearing and Blade Rest

3.4 Installation of Fixed Blades and Rotating Blades



WARNING!

Always take great care when handling the knives since they are very sharp and can cause personal injury. Use protective gloves!

Installation steps:

- 1) Lay the rotating blades into the knife groove in the knife rest to make them match and then cover the pressing block. Finally, screw the screws down to make the blade not sway.
- 2) Install the front and back pressing blocks and the fixed blades on the front and back boxes. Screw down the screws until the blade cannot sway anymore.
- 3) Measure the space between the fixed blade and the rotating blade using a steel rule. The normal space ranges from 0.2~0.3 mm. Adjust if the space is not in this range. Screw down the fixing screws between the fixed blade and the rotating blade.

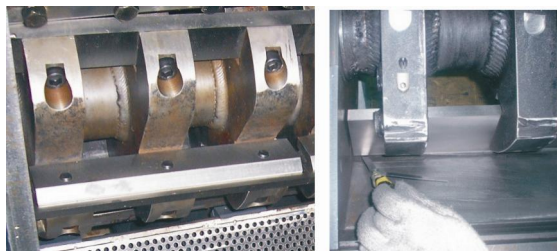

Picture 3-4: Installation of Fixed Blades and Rotating Blades



Caution!

Fixed screws must be tightened to avoid cutting and doing harm to

machine.



Caution!

The space between the fixed blade and the rotating blade cannot be too narrow to avoid damaging the cutting tool.

3.5 Installation of Belt Pulley and Motor

- 1) Interpose the key to the key groove and then install the driven wheel.
- 2) Lay lockup ring in the hole of the driven wheel and make both positions of the hole to match each other then screw the hexagon socket cap screw (M16mm×45).
- 3) Adjust the balance of the driven wheel with dial gauge. Stick the dial gauge to the driven wheel and rotate the driven wheel to see whether the value of the in dilator drops within 0~0.1 mm.
- 4) After balance, screw tightly the 3 hexagon socket cap screws.
- 5) Install the driving wheel in the bearing of the motor.
- 6) Put taper sleeve into the hole in the small pulley to make the hole aligned with the large pulley, then lock it up with inner hexagonal screw (M16mm × 30, the torque is 90 Nm).
- 7) Put the motor on the motor fixed board, and move it forward to reduce the spacing between small and large pulley.
- 8) Adjust the balance of the driving wheel and driven wheel: place spirit level between the driving wheel and the driven wheel to observe whether the mercury column is in the middle. If not, adjust the driving wheel (note: NOT the driven wheel) to make the driven wheel and driving wheel in balance.
- 9) Install the belt, push the motor rightward and screw tightly the position adjusting bolt to make the 4 belts be stressed by equal forces. Tighten the belts and screw down the position adjusting bolt.
- 10) Finally install the upper and lower protecting cover for pulley.

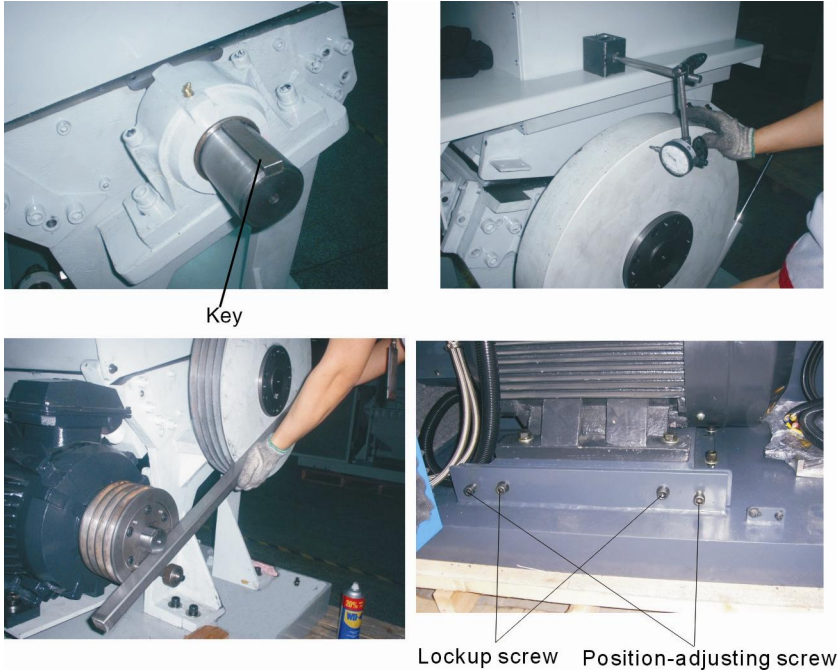

Picture 3-5: Installation of Belt Pulley and Motor

3.6 Installation of Regrind Storage Bin, Screen and Screen Bracket

- 1) Put the screen into the screen bracket and put the screen bracket under the cutting chamber.

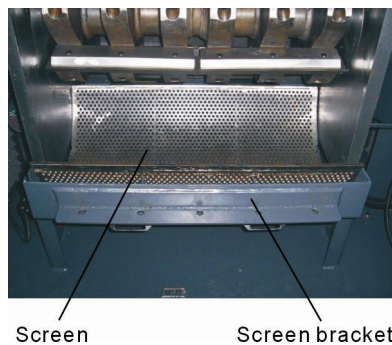

Picture 3-6: Installation of Regrind Storage Bin, Screen and Screen Bracket

- 2) Lift up the screen bracket again and lock it closely with the very front fixing pothook.



Note

Note! The screw must be tightened in this step, otherwise, a deformation

will occur in the screen bracket and thus results in the break of the screws.

- 3) Put the material collecting box under the screen bracket, and make them closed by putting material collecting box along bracket.
- 4) Lock the screw on the material collecting box tightly.
- 5) Turn the spring bolts on both ends of the regrind storage bin to fix the regrind storage bins.

3.7 Installation of Feed Box and Feed Inlet

- 1) Hoist the feed box to put it on the cutting chamber carefully to match.
- 2) Insert iron rod and fix it, install lockup screw and lock it up.
- 3) Install gas operated lever on the right side of feeding hopper.
- 4) Install seal ring on the base of feeding hopper.
- 5) Lock up feeding hopper and cutting chamber with star screw.
- 6) Install stainless fixing blocks on both sides of the feed box. Align the positions of the feed inlet and its holes. Tighten with screws and install them on the feed inlet.

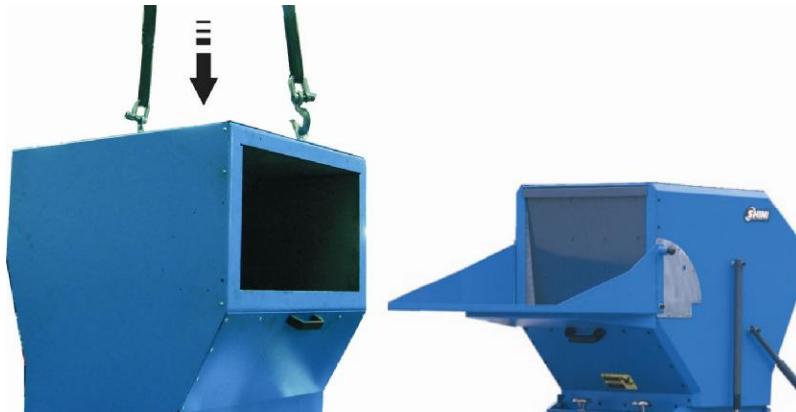

Picture 3-7: Installation of Feed Box and Feed Inlet

4. Operation Guide



Wear earplugs during operating to avoid personal injury!



Wear gloves during operating to avoid personal injury!



Wear goggles during operating to avoid personal injury!



Because the blades and rotor may be loosen, check the following items before operating:

- 1) If the blades has any damage.
- 2) If the surface of the rotor is loosen.

If any of the above situation is found, please contact local representative or SHINI company for help.

4.1 Startup Pretest

Unpainted part of the machine has been covered with stainless oil. Before use, the stainless oil should be cleaned.

- 1) Clean with a towel.
- 2) Wash with a towel dipping with amyl acetate.

4.1.1 Before the First Startup

- 1) Check whether the granulator is in the level state.



Note!

Adjust the machine to make its four holders to share the weight and be in a level state.

- 2) Check the space of the cutting tools (0.2~0.3mm) to see whether the lockup screws of the blades are tightened (fixed blade M16x75, rotating M20x66).

4.1.2 After First Startup for 2 Hours

- 1) Check the space of the cutting tools of the fixed blades and rotating blades

again; check whether the lockup screws of the blades are loose.

- 2) Check the position-adjusting screws of the motor and check whether the position-adjusting screws are tightened.

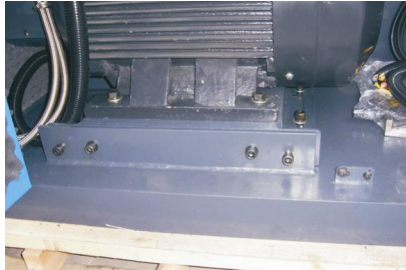

Picture 4-1: Position-adjusting Screws

4.1.3 After First Startup for 20~30 Hours

Check and adjust the belt's tensility after a 20~30-hour full-load operation.

4.2 Circuit Connection

The installation of the granulator's circuit must be conducted by the professional electricians.

Connect granulator to the power.

4.2.1 Check the Running Direction of the Motor

- 1) Open the door to check whether the feed box is closed.
- 2) Close the door.
- 3) Ensure the main power switch is in ON position.
- 4) Check the emergency stop.
- 5) Start the granulator via pressing the START button and stop the granulator via pressing the STOP button.
- 6) The granulator needs some time to fully come to a halt, After full stop, check whether the running direction is clockwise.



CAUTION!

The cutting tools may be damaged and the granulating capability will be reduced if there is a wrong running direction. Please disconnect the power and transpose any two wires of the three in the main power.

4.2.2 Check the Running Direction of the Blower

- 1) Check whether the running direction of the blower is in accordance with the symbol on the shield.
- 2) Connect to the power and stop again to check the blower's running direction.

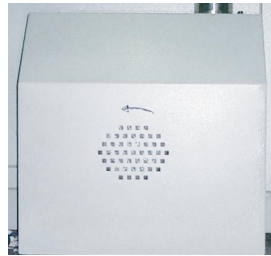

Picture 4-2: Blower



CAUTION!

If the blower's running direction is not in accordance with the symbol, the machine's working capability will be reduced by at least 25 percent. Under these circumstances, please disconnect to the main power and transpose any two wires of the three in the blower.

4.3 Open the Feeding Hopper, Screen and the Regrind Storage Bin



Before opening the feeding hopper, screen and the regrind storage bin, turn off the main power switch and the power switch of the granulator.



Be careful! The blade is very sharp, please take care.

4.3.1 Open the Feeding Hopper

- 1) Check if the feeding hopper and pulverizing room have been emptied. After that, turn off the main power supply.
- 2) Loosen the long star screw and open the door.
- 3) Loosen the lock clip of the hopper.
- 4) Open the hopper backward.



CAUTION!

The feeding hopper is held by pneumatic stick to avoid its dropping when opening it.

4.3.2 Open the Regrind Storage Bin and Screen

- 1) Turn off the power switch of the granulator.
- 2) Loosen the star screw and open the door.
- 3) Loosen the quick coupling hoop in the end of the outfall pipe and transfer it to one side.
- 4) Open the spring bolt and take out the regrind storage bin.
- 5) Screw off the hexagon socket cap screws in the pothook to loosen the pothook.
- 6) Take out the screen bracket and withdraw the screen.

4.4 Close the Screen Bracket; the Regrind Storage bin and the Feeding Hopper



CAUTION!

Before opening, clean the interface. Take care! **DO NOT** be squeezed!



Picture 4-3: Close the screen bracket; the regrind storage bin and the feeding hopper

4.4.1 Installation of the Screen Bracket and the Regrind Storage Bin

- 1) Put the screen into the screen bracket and put the screen bracket under the cutting chamber.
- 2) Lift up the screen bracket and lock it closely with front block.



Note!

Screw must be locked tightly, or else screen bracket will be out of shape and screen fracture.

- 3) Put the material collecting box under the screen bracket, and make them closed by putting material collecting box along bracket.
- 4) Lock the storage box tightly with screw.

4.5 Turn Off and Stop the Granulator

The granulator is controlled by main power switch, safety switch, START / STOP button and emergency stop.

Main power switch:

Main power switch of pulverizer is located at the front control panel. Through rotating the main power switch to control the 'on' or 'off' of the power supply.



Picture 4-4: Circuit switch

START button and STOP button:

These two buttons control the startup and stop of the machine.

Emergency stop:

When an accident happens, this button can do a favor.



CAUTION!

If there are ungrinded crew materials in the feed box or cutting chamber, the granulator shall NOT be stopped, otherwise the crew materials will blockade the rotator and the motor will be overloaded next time you start the machine up.

4.6 Blades Installation Adjusting

All the cutters, including rotating blades and fixed knives, can be adjusted within clamp outside the machine.

Put all the cutters including rotating knives and fixed knives into clamp, adjusting its adjusting screw until the screw reach the clamp.

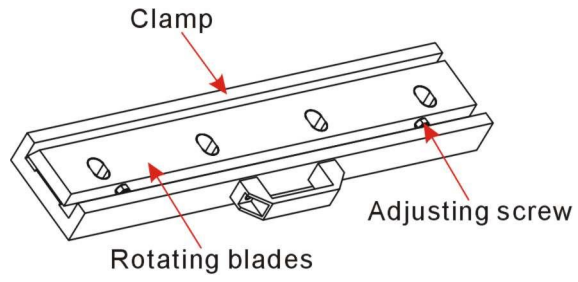

Picture 4-5: Blades Installation Adjusting

5. Trouble Shooting

5.1 Granulator Can Not Work

- 1) Check if the emergency stop has not been reset. If not, rotate the Button anti-clockwise to reset it.
- 2) Check whether the door is closed. If not, the machine could not be started.
- 3) Check if the feed box is completely closed. If not, the machine could not be started. Then, check the lockup clip after opening the door.
- 4) Check the motor's overload protector. The overload protector in the electrical control box will work if the motor overloads. Under that situation, (A) (the green pole) will sprout. Press the Reset button (B) to reset it. Before startup again, check whether there is any powder in the granulator.
- 5) Check the overload protector of the feeding blower's motor. If the feeding blower does not run, the granulator cannot run either. Check the motor protector in the electric control box. If it is closed, the switch will be in 0 positions. Reset it to 1 position. (A) (The green pole) will sprout. Press the Reset button (B) to reset it.
- 6) Check the space between blades A stop will happen or the motor overload protector will work if the blade is very blunt or the space between blades is not correct. More details about checking, replacing and readjusting the blades to see chapter 3.3.

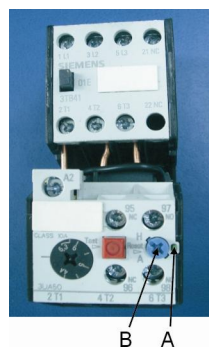

5.2 Stop Due to Other Reasons

Connection failure or looseness of safety switch or limit switch can also result in operation failure.



Note!

Do not disconnect to safety switch or control switch.

6. Maintenance and Repair

Check whether the material stopper is damaged. Period: daily

Check whether the emergency stop is normal. Period: Daily

Check whether the safety switch is normal. Period daily

Check whether the screw of the screw bracket is tightened. Period: Daily

Check the start/stop button. Period: Daily

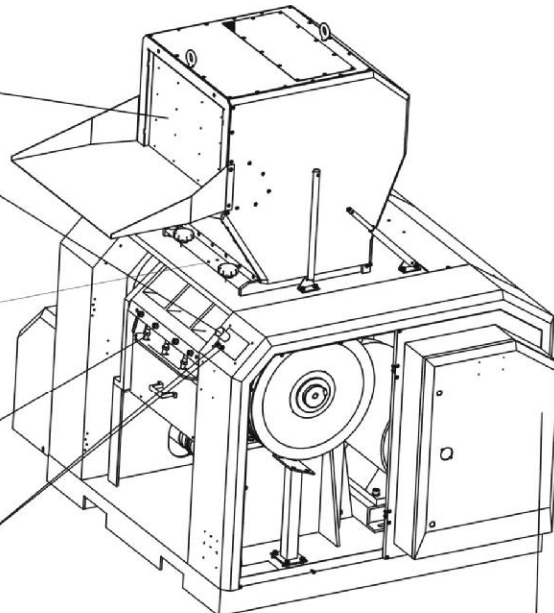

Check whether the connectors of the electric elements in the control cabinet are loosened. Period: Weekly

Check whether the screw of cutters is loosened and the wearing condition of the cutters and screen bracket. Period: Monthly

Regularly add lubricant in the bearings. Period: Monthly

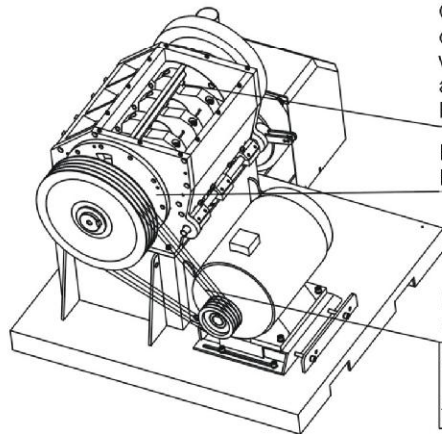

Check whether the belt is damaged. Period: Monthly

Check the belt tension. Period: Semiyearly (or after a full load running of 20-30 hours.)

6.1 Repair

All the repair must be done by professionals to avoid damage to machine and harm to human body.

6.1.1 Replace the Blades



CAUTION!

Warning: Self- rotation exists due to non-balanced forces or unstable barycenter.



Wear gloves to avoid being cut and be careful of the sharp blades!



More details about replacing or maintaining the blades to see chapter 3.4. Inject screw thread fixing glue (blue LOCTITE 243 recommended) tighten all fixing screws to fix the screws.



CAUTION!

To decrease the possibility of harm to other people, the replacement action must be conducted by oneself.

To avoid self- rotation, block the rotating blade with a thick wood block. After replacement, check whether the screen is damaged. If so, replace the screen. Each time to replace the blade, the screw and insulation ring must be replaced also. Before replacing the blades, open the door and feed box, remove the regrind storage bin, screen and screen bracket.

1) Remove the rotating blades



CAUTION!

To avoid self rotation, block the rotating blade with a thick wood block.

1. Remove the screws and insulation rings.
2. Remove the blades.
3. Clean the installation surface of the blades.

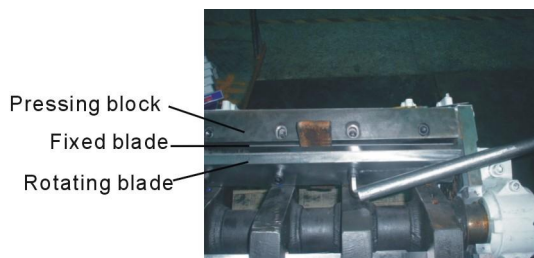

Picture 6-1: Remove the Rotating Blades

2) Remove the fixed blades

1. Revolve the screw of the front fixed blade.
2. Loosen and remove the hexagon socket cap screw.
3. Remove pressing block and blade, clean the blade rest.
4. Loosen and remove the screws of the back blades.
5. Loosen and remove the hexagon socket cap screw again, remove the pressing block and blade. Clean the supporter box.

3) Install the blades

Clean carefully the fixed blades and rotating blades and then install them.



CAUTION!

Each time to replace the blade, the screw and insulation ring must be replaced also. More details about replacing or maintaining the blades to see chapter 3.4.

6.2 Transferring



Maintenance or repair the transmission belts after pressing down the emergency stop button or main power switch!

6.2.1 Daily Maintenance of V Belts

There are four V belts according to motor power.

1) Check the V belts

Check V belts' tensility after a full-load operation for 20-30 hours. And then check its abrasion condition.

2) Check V belts' tensility every 6 months.

Remove the upper panel in the back end of the granulator. Rotate the V belts for several circles to see if there is any damage.



CAUTION!

Pinch risk! Do not place your hands between wheels and the belts.

If it is necessary, check the belt's tensility via enforce extra force (75N) and measure its excursion. This extra force is determined by power and frequency of the motor. More Details to see the following table.

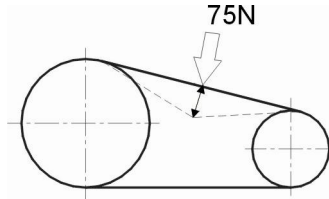

Picture 6-2: Daily Maintenance of V Belts

Motor 50Hz	18.5 / 22kW	30 / 37kW	45-55kW
New belt	15mm	14mm	15mm
Old belt (Six- month later))	19mm	19mm	19mm
Motor 60Hz	18.5 / 22kW	30 / 37kW	45-55kW
New belt	18mm	17mm	16mm
Old belt (Six- month later)	23mm	23mm	20mm

6.2.2 Adjustments of V Belts

1. Remove the upper panel and feeding plate in the back end of the granulator and open the box door.
2. Open the quick coupling clip in the end of the outlet pipe and remove the regrind storage bin.
3. Adjust the belt's tensility via changing the space between the driving wheels and the driven wheels with two moving screws.
4. Lock up the two moving screws. Recheck the belts' tensility after a full-load operation for 20-30 hours.

6.3 Lubrication

6.3.1 Lubricating Oils

Xin Chang Long: FX-00

FX-000

Bp: BP Grease LGEP 2

ESSO: Beacon Ep2, Beacon EP2

Mobil: Mobilux EP2

Shell: Shell Alvania EP2

Texaco: Multifak Ep2, Novotex Grease EP2

6.3.2 Please Grease the Bearing with Lubricating Oils Periodically

Inject lubricating oil via throat with an oil greaser. If the granulator is not used for a long time, please grease anti-rust oil in blade rest, fixed blade, rotating blade, cutting chamber and screws to avoid dust.



Picture 6-3: Oil throat

6.4 Maintenance

6.4.1 Daily Check

- 1) There is rubber shutter in the feed box. If the rubber shutter is damaged, replace it immediately. Otherwise the fragment of the shutter will damage the blades in the cutting chamber.
- 2) Check whether the Emergency Stop works properly. Start the machine and then stop it via Emergency Stop. Rotate the button anti-clockwise to reset the Emergency Stop.
- 3) Check star screw, safety screw is part of granulator' safety system, its length is pre-designed, when the screw is loosen, the granulator will stop working so to protect the machine. The thread length of the safety screw is 90mm, damaged screw needs to be replaced by a new one.

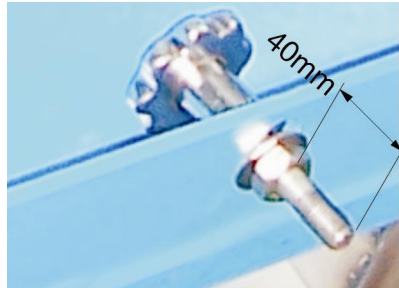

Picture 6-4: Star Screw

6.4.2 Weekly Check

- 1) Check the power wire to see whether there is any damage. If so, replace it immediately.
- 2) Check the safety switch.

6.4.3 Monthly Check

- 1) Check the belt to see whether there is some damage. Check the belt's tensility every 6 months. More details to see chapter 6.2 Transmission.
- 2) Check the blades and screws to see if they get loose.

6.5 Cleaning



CAUTION: The blade may do harm to human body when opening the feeding hopper!

- 1) Check whether the feed box is emptied before stopping the machine.
- 2) Clean the exterior surface of the feed box.
- 3) Turn off the main power switch.
- 4) Clean the shutter of the feed box with a dust separator.
- 5) Loosen star screw.
- 6) Open the feed box backwardly.



Note!

The feed box is held by pneumatic spring, therefore it cannot fall down.

- 7) Clean the interior surface of the feed box.
- 8) Clean the interior surface of the feed box.
- 9) Open the door and remove fast pipe connector from one end of the pipe.



Note!

Lift the regrind storage bin in both hands so it would not fall down.

- 10) Loosen the lock wiring in the screen bracket and remove the screen bracket.
- 11) Take out the screen.
- 12) Hold to the screen and take it out outwardly.
- 13) Clean the regrind storage bin, screen bracket and the screen.
- 14) Clean both surfaces of the cutting chamber.
- 15) Clean every transmission pipe, blower, and cyclone dust separator.
- 16) Clean the wheels with bright dust-precipitator.

Reinstall after cleaning



CAUTION!

Take care not to be squeezed when closing the door!

- 1) Install the screen bracket.
- 2) Lift the handle of the screen bracket and push it into front block tightly.
- 3) Put the storage box under the screen bracket, and make them closed by putting storage box along bracket.
- 4) Lock the screw on the material collecting box tightly.
- 5) Install the fast pipe connector at the end of the extraction line.
- 6) Close the door.
- 7) Close the feed box.
- 8) Lock the two long star screws on the feed box.
- 9) Install the material feeder.
- 10) Check if the feed box is emptied.
- 11) Open the main power switch.
- 12) Start the machine.

6.6 Maintenance Schedule

6.6.1 About the Machine

Model _____ SN _____ Manufacture date _____

Voltage _____ Φ _____ V Frequency _____ Hz Power _____ kW

6.6.2 Check After Installation

- Check if pipe connections are firmly locked by clips.
- Check the gap between fixed blade and rotating blade. (0.2~0.3mm).
- Check the rotating balance of the belt wheel.

Electrical Installation

- Voltage: _____ V _____ Hz
- Specs of the fuse: 1 Phase _____ A 3 Phase _____ A
- Check phase sequence of the power supply.
- Check the rotating direction of the conveying blower.

6.6.3 Daily Check

- Check main power switch.
- Check emergency stop button.
- Check start / stop button.
- Check material check plate (strip) is perfect or not.
- Check whether emergency stop and safety switch works normally.
- Clean screen and feeding hopper.
- Check whether start, stop and power switches are normal.

6.6.4 Weekly Check

- Check all the electrical cables.
- Check if there are loose connections of electrical components.
- Check the start and stop function of the electrical handspike
- Check function of all the safety switch
- Check the cooling system of the cutting chamber
- Check blade condition.
- Check whether set screws in fixed and rotate blades are under looseness.
- Check if there is abnormal noise, vibration and heat in reduction gear.
- Check the cracking window

6.6.5 Monthly Check

- Check the status of the belt.
- Check the overload protection function of the motor.
- Check motor reversed running function.
- Check the tightness of the blades.
- Check the pneumatic stick
- Check start/stop delay function of the conveying motor
- Check whether clamp ring of pulley is fastened.
- Check belt tension.

6.6.6 Check Half-yearly or Every 1000 Running Hours

- Check belt tension
- Check the bearings, motor and shaft lubrication
- Check the shaft holder
- Valuation of machine performance

6.6.7 3 year Checking

- PC board renewal.
- No fuse breaker renewal.